

PROPOSED SITE LAYOUT LEGEND

- STANDARD DUTY ASPHALT PAVEMENT PER DETAIL
- HEAVY DUTY ASPHALT PAVEMENT PER DETAIL
- STANDARD DUTY CONCRETE PAVEMENT PER DETAIL
- HEAVY DUTY CONCRETE PAVEMENT PER DETAIL
- CONCRETE SIDEWALK PER DETAIL
- GRAVEL SURFACE PER DETAIL
- CHAIN LINK FENCE
- WOOD FENCE
- GUARDRAIL
- SIGN
- BOLLARD
- POLE MOUNTED SITE LIGHT
- HANDI-CAP PARKING SYMBOL
- DIRECTIONAL ARROW PAVT. MARKING
- PROPOSED PARKING SPACES
- SITE LAYOUT CODED NOTE

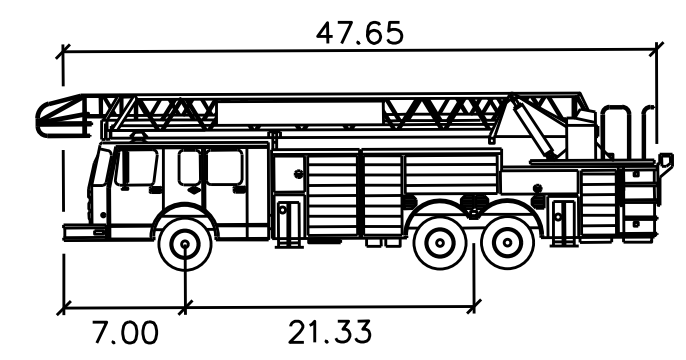

100' Aerial Cat Platform
 Width : 7.00 feet
 Track : 21.33 feet
 Lock to Lock Time : 6.0
 Steering Angle : 33.4

PRELIMINARY
 NOT FOR CONSTRUCTION

NO.	DATE	BY	DESCRIPTION
	08/27/17	MTB	PLANNING COMMISSION APPLICATION
	09/27/2017	MTB	REVISED PLANNING COMMISSION APPLICATION
20226 MERCANTILE ROAD BEACHWOOD, OH 44122 TEL: 216.378.1490 FAX: 216.378.1497		PROJECT DATE:	SEPT 2017
		PROJECT NO.:	T1730015
		DRAWN BY:	JKZ
		CHECKED BY:	MTB
 Mannik Smith GROUP www.MannikSmithGroup.com			
PREPARED FOR:			
TRILOGY HEALTH SERVICES, LLC 303 N HURSTBOURNE PKWY, SUITE 200 LOUISVILLE, KY 40222			
PROPOSED CONTINUUM OF CARE FACILITY DAVIDSON RD AND BRITTON PKWY HILLIARD, OH 43026			
FIRE TRUCK TURN			
1			1